



OUTDOOR DIGITAL SIGNAGE

LARGE SIZE FORMAT APPLIED SCREEN

CLASS	MODEL
32"	H325MSI

KEY FEATURES

- Special DOOH LCD Panel
- All Weather Capable
- Sunlight Readable
- Anti-Vandal Protection
- Air-Looping System
- Auto Brightness Control
- Remote Control (RS232)
- Easy to Service with Front Door Open
- Cabinet Housing Color : RAL7040
- Capacitive Touch applied



Broadcast your branding with Hyundai Digital Signage!

HYUNDAI's outdoor displays represent state-of-the-art display technology for any outdoor environment. Meeting the highest industrial standards they provide a high degree of operational reliability and superior quality image, which are essential preconditions for attracting the attention of your target audience.



SPECIFICATIONS

Model	H325MSI	
Panel	Screen Size (diagonal)	32"
	Active Display Area (inch/mm)	27.496 x 15.467 698.4 x 392.85
	Resolution	1920 x 1080
	Aspect Ratio	16:9
	Display Colors	16.7 M
	Brightness (cd/m ² ; typ.)	2000
	Contrast Ratio	1300:1
	Response Time (ms; GTG)	25
	Viewing Angle	178°/178°
	Lifetime (hours)	30,000
Touch Screen	Backlight type	LED
	Response Time (ms)	50 ~ 100
	Interface	USB 2.0
	Touch Intensity	Permanent (protected by glass)
Input	Detection Method	PCT
	VGA (15pin D-Sub)	1
	HDMI	1
	DVI	1
Power	RS-232C	1
	Operating Voltage	100 – 240VAC
	Consumption (typ.)	600W (Without PC)
	Consumption per nits (max.)	0.26W
Features	Heater Block (with PC Case)	850W / Peak 1.2KW
	Auto Cooling System	Yes
	Auto Heating System	Yes
	Anti-Vandal Glass	Yes (8mm = 3mm+3mm)
	Anti Reflection Coating	Yes
Operation	Auto Brightness Sensor	Yes
	Temperature (°C)	-30 ~ 50
	Humidity (%)	20 - 80
	Storage (°C)	-40 ~ 60
Approvals	OSD Language	10 Lang
Approvals	Ingress Protection	IP65
Dimension	Set (W x H x D), inch/mm	44.09 x 23.23 x 6.30 1120 x 590 x 160
Weight	Set (lb/kg)	136.7 / 62
Mounting	Wall mounting (Built in)	
Computer	Option	

FEATURES

All Weather Capable

Equipped with an intelligent cooling and heating system, HYUNDAI's Outdoor Displays are well suited for withstanding any weather conditions from -30°C to +50°C.

Sunlight Readable

HYUNDAI provides special displays which are based on the Optical Bonding for installations in environment with the brightest lighting conditions. Make your messages and images clear and readable under even bright sunlight.

Anti-Vandal Protection

Thanks to a special tempered security glass, HYUNDAI's Outdoor Displays are protected against any vandalism attacks using Anti-Vandal glass bonding technique improving in durability from outside damage.

DIMENSIONS

[Unit : mm [inch]]

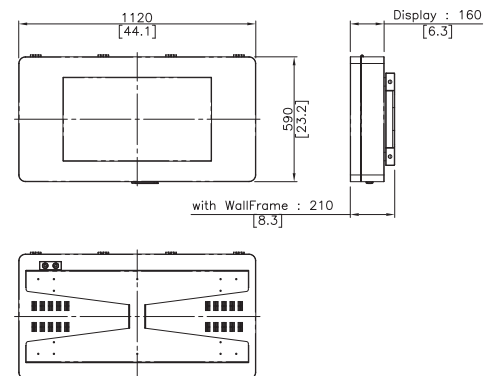

Specifications and design are subject to change without notice. See our website for detailed information.

UPDATE : MAR. 2015

HEAD OFFICE - HYUNDAI IT CO., LTD.
 S-20 Garden5 Tool 8F, Chungmin-ro, Songpa-gu, Seoul,
 138-962 Korea
 Tel. +82 70 7008 0110 E-mail: prio123@hyundaiit.com
 www.hdit.co.kr

HYUNDAI IT AMERICA CORP.
 2051 Junction AVE., Suite 112 San Jose, CA 95131, USA
 Tel. +1 408 954 8920 email : sales@hyundaita.com
 www.hyundait.com

HYUNDAI IT EUROPE GMBH
 Siemensstrasse 22, 63225 Langen, Germany
 Tel. +49(0) 6103-38878-100 email : info@hyundait.eu
 www.hyundait.eu

HYUNDAI IT JAPAN
 Kawaziri Bldg 2F, 534 Waseda Tsurumaki-cho,
 Shinjuku-ku, Tokyo, Japan
 Tel. +81-3-6273-9652 email : sales@hyundaiit.co.jp
 www.hyundaiit.com